

PAPER • OPEN ACCESS

## Substantiation of Structure of Adaptive Control Systems for Motor Units

To cite this article: S I Ovsyannikov 2018 *J. Phys.: Conf. Ser.* **1015** 032180

View the [article online](#) for updates and enhancements.

### Related content

- [An adaptive control system for a shell-and-tube heat exchanger](#)  
M V Skorospeshkin, M S Sukhodoev, V N Skorospeshkin et al.
- [Adaptive control system of dump truck traction electric drive](#)  
O M Bolshunova, A A Korzhev and A M Kamyshyan
- [Controlling System Based on DSP for BLDC Motor](#)  
Zhou Yu, Bai-Na Su and Yu-Shan Zhang



**IOP | ebooks™**

Bringing you innovative digital publishing with leading voices to create your essential collection of books in STEM research.

Start exploring the collection - download the first chapter of every title for free.

# Substantiation of Structure of Adaptive Control Systems for Motor Units

**S I Ovsyannikov**

Belgorod State Technological University named after V.G. Shukhov, 42, Kostyukova Street, Russia, Belgorod, 308012

Email: [ovsrg@mail.ru](mailto:ovsrg@mail.ru)

**Abstract.** The article describes the development of new electronic control systems, in particular motor units, for small-sized agricultural equipment. Based on the analysis of traffic control systems, the main course of development of the conceptual designs of motor units has been defined. The systems aimed to control the course motion of the motor unit in automatic mode using the adaptive systems have been developed. The article presents structural models of the conceptual motor units based on electrically controlled systems by the operation of drive motors and adaptive systems that make the motor units completely automated.

## 1. Introduction

Walking tractors and motor units are not only the smallest in size and weight among the mobile vehicles, but also the most commonly used units. Nowadays the machines on the basis of walking tractor and motor unit (MU) are used in agriculture, forestry, communal services and construction. Unlike other transportation means, the motor units possess high maneuverability, which makes them indispensable in shallow-contour areas with complex configuration.

Operation of a motor unit is performed by an operator through the control bars by applying physical efforts. In addition, an operator is involved into the process of traction dynamics by pushing or holding the unit, as well as he/she adjusts the depth of processing by working bodies, moving the control bars in a vertical plane. In general, it can be noted that the MU operator significantly expends physical strength than an operator of a tractor. This fact is confirmed in the works of other researchers [1].

Based on the research conducted by the author, the destabilizing factors of MU operation have been established and put into the following groups:

- withdrawal from a given trajectory as a result of a change in the coupling properties of propellers with the support base as a result of redistribution of the coupling mass along the sides, displacement of the vector of pulling force of the unit, redistribution of the torque and other factors;
- deviation of working bodies from a given position in height and width under the influence of changing properties of the medium being treated;
- reduction or loss of the coupling properties of propellers with the support base, which is expressed by increased slippage or disruption to full skidding;
- failure of MU stability in the transverse and longitudinal planes under the action of dynamic and static forces aimed at tilting.

MU stabilization is reached by an operator applying his/her physical efforts. On the basis of the research works carried out by the author [2], it is established that the operator expends significant



efforts comparable to his ultimate physical capabilities. This leads to frequent and long stops for him/her to get some rest, which generally reduces the performance of MU.

The design solutions are mostly aimed at technical improvements, but not to the reduction of physical strain on an operator of MU. To solve the problem, automatic control systems have been offered in this work, the purpose of which is to justify the structure of mobile equipment control system, in particular motor units.

## 2. Materials and methods

This article considers the control system possibilities of the machines, in particular MU. The results of work are needed for the development of mathematical model of the control system, justification of choice of the type of sensors and their operation optimization and actuators, depending on the tasks assigned.

## 3. Results and clarifications

To reduce physical load of an operator and improve working conditions, taking into account the evolution of technology, the following steps have to be taken:

- to apply amplifiers based on mechanical, hydro-, electro-, pneumatic drives;
- to apply automated and automatic systems operating in accordance with a given algorithm;
- to use the adaptive systems that can adjust to changing destabilizing factors. Adaptive systems are more complex; however, they are more effective.

To apply control systems for mobile machines, in particular MU, the following steps have to be accomplished:

- to provide a separate drive for each propeller;
- to provide individual control of the operation of separate drives of propellers;
- to equip the MU with motion control sensors: course direction, speed, slippage, obstacles on the way of movement, etc.;
- to equip the MU with the system of analysis and decision-making programmers (for adaptive systems).

A separate drive for propellers can be provided in several ways: by means of mechanical, hydraulic and electric transmissions. Having analyzed the advantages and disadvantages of several drives, it should be noted that the mechanical transmissions are difficult to manufacture from the point of view of technology. Besides, they are metal-intensive and thereof their cost is high; however, they have high mechanical efficiency. In this case the disadvantage would be low energy transfer from the source to different consumers.

Among the hydraulic transmissions, the most widely used are high-speed transmissions (gear-type and axial-piston hydraulic motors). The development of low-speed high torque hydraulic drives is in the process now [3]. The manufacture of hydraulic drive equipment requires high precision and manufacturability, which affects their cost. High-speed drives need to be equipped with the reducing gears. Low-speed hydraulic drives are rather bulky. The hydraulic drive control systems are complicated both constructively and technologically in production. In general, the disadvantages of the hydraulic drives would be their low efficiency, fairly complex control systems and high costs. Advantages would be the transportation of large capacities.

The electric drive is by far the most mobile system. Electric drives are built inside the wheel or propeller, in the drive of working bodies or individual machines and equipment. Until recently, the use of the electric drive was limited by a number of drawbacks: the use of collector motors was limited by insufficient reliability due to the rapid wear of brushes and a collector, the use of asynchronous motors was limited by the high cost of control systems of the drive shaft speed. Once the valve motors were introduced on the market, these deficiencies had been eliminated. The valve motors are the motors of asynchronous type with a permanent magnet rotor. The frequency and direction of rotation of the rotor are controlled by the controller [4]. The control systems of fan motors are quite simple and reliable in operation.

One of the advantages of the electric drive of mobile machines is the rational use of energy; excluding the work of engines at idle. Energy sources can be the batteries, DC generators with a drive from the internal combustion engines and their combination, i.e. hybrid drives.

The movement of MU is effected by the tangential forces of thrust  $Pt$  (Figure 1), developed by propellers, forces of external resistance, including the forces of resistance to movement  $Pf$  and tractive resistance of the  $Pcr$  unit. In those cases when the power balance along the sides of MU is not the same, the aggregate moves away from the given trajectory of motion by angle  $\Theta$ . Direction Stabilization of movement is carried out by an operator when he or she applies physical efforts to the control rods. *Pop.cont.*, i.e. the operator performs the functions of the stabilizing element.

Let us consider way the functioning of the existing MU structures in more detail. Fuel  $T$  from the tank (Fig. 2) enters metering device  $K$  (carburetor, fuel pump, etc.) and is fed to the engine, where it is converted into rotational energy on the crankshaft, which is characterized by torque  $Mcr$  and the angular velocity of rotation  $\omega_i$ . The operating mode of the engine is set by speed controller  $P$  (usually the centrifugal type), depending on the change in the value of the external load. By changing the position of the controller with arm force  $Pop.f$ , an operator sets the operating mode of the engine.

The mechanism of energy transfer consists of a clutch, gearbox, transfer case, main gear, differential, on-board transmissions and other mechanisms and devices.

The operator's functions are as follows:

- to control the operation of the clutch
- to switch the gearbox transmission
- to control the operation of the differential.

As some types of a moving tractor are equipped with a belt clutch, the operator is forced to constantly hold the clutch engagement lever in the depressed state, which leads to his rapid physical fatigue.

Control of differentials depends on their design features. Permanently blocked (mainly applied for light and medium walking tractors and motor units) and permanently unlocked differentials (heavy walking tractors and motor units) are applied on a regular basis. Unlocking permanently locked differentials is performed during turns and steep turns, in the blocked mode, the propeller slips in the contact spot under the rotation of a walking tractor frame by the physical effort of an operator. Constantly unlocked differentials are blocked by an operator in case of significant change in the coupling properties of propellers along the sides by keeping the locking lever in the pressed position *Pop.diff.*

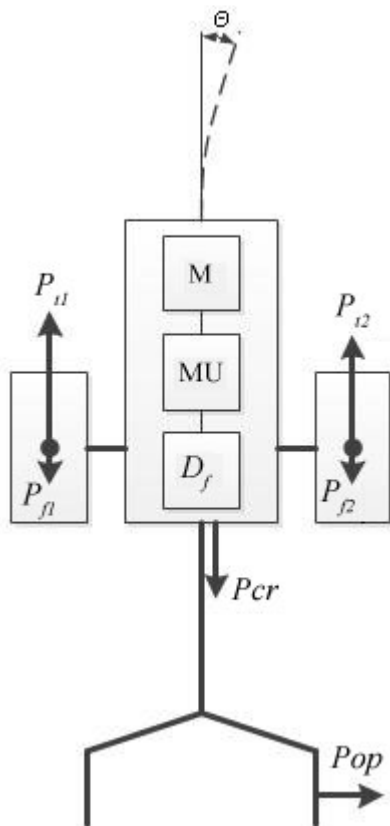

**Figure 1.** A diagram of forces of the motor unit.

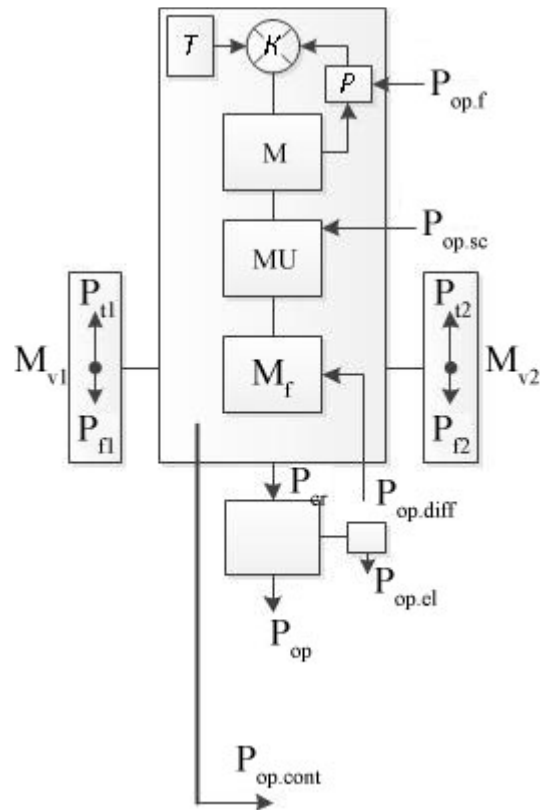

**Figure 2.** A block diagram of the motor unit with a mechanical transmission.

The propellers transverse the applied torque to pulling force  $P_t$ , which is necessary for implementation of the external resistance of forces – the resistance to the movement of moving tractor  $P_f$ , the resistance of the working bodies of unit  $P_{op}$  and its support elements  $P_{op.el}$  (wheels, shelves, skis, etc.). Independent movement of MU will be performed under the following condition:

$$P_{t1} + P_{t2} \geq P_{f1} + P_{f2} + P_{cr}. \tag{1}$$

If the condition is not fulfilled, i.e. the coupling properties of propellers are not sufficient enough; the operator is forced to compensate for the deficit of the power balance, applying the efforts of the  $P_{on}$  in the direction of motion. In this case the balance of power can be presented as follows:

$$P_{t1} + P_{t2} + P_{op} \geq P_{f1} + P_{f2} + P_{cr}. \tag{2}$$

In this case, the operator performs stabilization functions on the actions of destabilizing factors of traction dynamics of MU by external resistance forces.

In general, making physical efforts, an operator participates in the processes of generation of a given course motion, traction dynamics, engine operation, coupling and differential.

To gain the main objective of this work, it is necessary to exclude physical efforts of an operator in the operation of MU. For this purpose, the author developed the design of MU, the block diagram of which is shown in Fig. 3. D-valve motors are used in this work, which are equipped with a reducing gear. Operation mode change of the engines is carried out by controllers  $K$ , which convert the supplied energy depending on the control signal of controller  $P$ . DC batteries are the energy sources. To increase the resource capacity, it is possible to install a generator with a drive from an internal

combustion engine. Taking into account that the motor unit is operated in close proximity to the households, charging the batteries does not cause any major problems.

The operator's functions are reduced to changing the operating modes of regulators  $P_1$  and  $P_2$  by moving the control levers, overcoming the tensile forces of the regulator springs. In those cases where the change in the direction of the course movement is faster, the operator has time to react through the regulators. It is forced to correct deviation from the given trajectory by physical efforts through the control rods. Improving the traction and coupling properties is ensured by the increase of the coupling weight by ballasting and by the use of transformable wheel-caterpillar propellers. In general, the operator spends much less physical energy, nevertheless, he is forced to constantly monitor the direction of movement and adjust the course direction by moving the knobs of the regulator. This activity affects his mental fatigue and leads to a gradual decrease in the reaction.

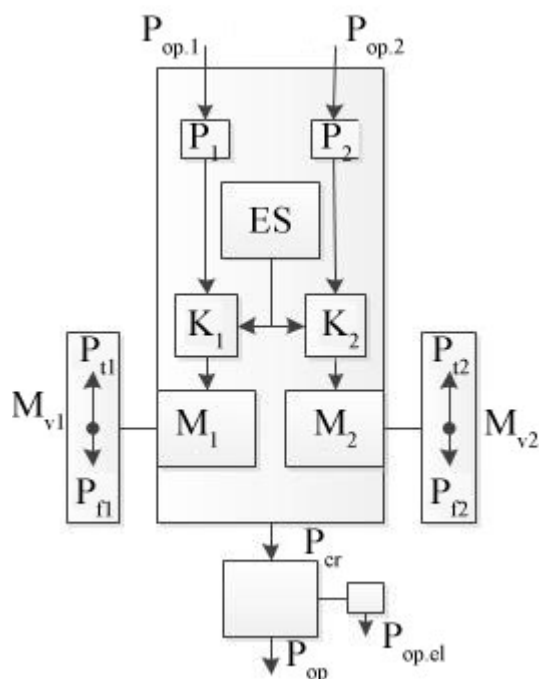

**Figure 3.** Block diagram of the motor unit with the separate drive of propellers.

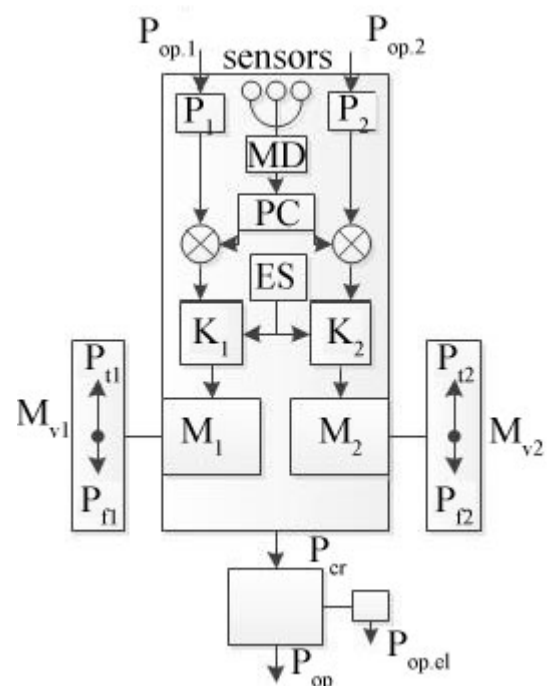

**Figure 4.** Block diagram of the motor unit with the adaptive motion control system.

Therefore, the next MU improvement stage is the application of adaptive motion control systems (Fig. 4). The functions of monitoring and correcting the motion direction are assigned to a system consisting of a sensor unit and measuring device  $MD$ . A signal from measuring device  $MD$  is processed by an on-board computer, where it is analyzed according to the specified program of motion and decision making in accordance with the specified algorithm. As a result of processing, the computer sends a control signal to controllers  $K_1$  and  $K_2$  managing drive motors  $M$ .

Sensors and color sensors, accelerometers, gyrocompasses and electronic compasses, as well as GPS systems, are used as traffic control sensors.

The operator's functions are reduced to the selection of a program of the technological process, the type of control of driving modes, the modes of operation, the algorithm for adapting the system - to the destabilizing factors. The operator is forced to apply physical efforts only in emergency cases, when the adaptive system is not able to overcome the effect of destabilizing factors.

Adaptive control systems can be applied for transport-technological units: bogies, mowers, communal and construction equipment, etc.

#### 4. Outcome

Basing on the analysis of the influence of structures of various drive devices, it was found out that the most optimal would be an electric drive based on valve motors and an electronic motion control system. It is recommended to use a rechargeable battery or a hybrid drive as an energy source. The next step in the development of MU would be the application of adaptive motion control systems of MU based on motion control measuring devices and an analytical decision-making unit. The use of the adaptive systems will make the process of technological operations fully automated.

#### 5. Acknowledgement

The article is prepared in the framework of development of the Base University on the basis of BSTU named after V.G. Shukhov.

#### References

- [1] Keller N 2003 *Tractors and agricultural machines* **4** 7-10
- [2] Ovsyannikov S 2013 *Motrol* **7** 45-50
- [3] Remarchuk M P, Chmuzh Ya V, Bayramashvili T T, Ovsyannikov S I 2010 Creation of hydromotors is on the basis of the use of standard power hydrocylindersю *Naukoviy visnik budivnictva* **57** 430-434
- [4] Pankratov V V 2007 *Electronic components* **2**
- [5] Ilina A G, Lukichyov D V, Usoltsev A A 2008 *Mechanical Engineering*. **6** 63-67
- [6] Ademiluyi Y S, Ozoemena Ani A, Ugwuishiwu B O and Oyelade O A 2010 *Nigerian journal of technology* **26(1)** 59-66
- [7] Kuzmin N V 2005 *Mechanization and electrification of agricultural production* **10** 6 – 8
- [8] Malesa V 2012 *Motrol* **13** 136-144
- [9] Carrithers J A, Williamson D L, Gallagher P M, Godard M P, Schulze K E and Trappe S W 2000 *Journal of Applied Physiology* **88** 1976-1982
- [10] Loveikin V, Romasevich U 2012 *Motrol* **14-3** 158-163
- [11] Ovsyannikov S, Remarchuk N 2010 Aspects of functional stability of aggregates based on walking tractors *Agricultural machinery Collection of articles* **20** 234-242
- [12] Ahlborg B, Bergstrom J, Ekelund L G and Hultman E 1967 Muscle glycogen and muscle electrolytes during prolonged physical exercise. *Acta Physiologica Scandinavica* **70** 129-142
- [13] Macmillan R H 2002 The mechanics of tractor-implement performance: theory and worked examples: a textbook for students and engineers Printed from: <http://www.eprints.unimelb.edu.au>