

PAPER • OPEN ACCESS

Modeling and analysis of dynamic characteristics of carrier system of machining center in MSC.Adams

To cite this article: A V Grinek *et al* 2018 *IOP Conf. Ser.: Mater. Sci. Eng.* **327** 022088

View the [article online](#) for updates and enhancements.



IOP | ebooks™

Bringing you innovative digital publishing with leading voices to create your essential collection of books in STEM research.

Start exploring the collection - download the first chapter of every title for free.

Modeling and analysis of dynamic characteristics of carrier system of machining center in MSC.Adams

A V Grinek¹, A V Rybina¹, I P Boychuk², I M Dantsevich², A V Hurtasenko¹

¹ Belgorod State Technological University after V.G. Shukhov, 46, Kostyukova St., Belgorod, 308012, Russia

² Admiral Ushakov Maritime State University, 93, Lenina Av, Novorossiysk, 353918, Russia

E-mail: grinyokann@gmail.com

Abstract. The simulation model with the help of vibration analysis was developed in MSC.Adams/Vibration and experimental research of the dynamic characteristics of a five-axis machining center was carried out. The amplitude-frequency characteristics, resonant frequencies in various directions are investigated. Dynamic and static rigidity, damping intensity and the coefficient of dynamism of the center are determined.

1. Introduction

Vibrations arising during the machining of details lead to a decrease in the quality of the treated surface, reliability of work and deterioration of the equipment. Research of the dynamic characteristics of the machine makes it possible to eliminate the coincidence of intrinsic and perturbing frequencies, in particular, by controlling the cutting mode [1, 2] or by optimizing the design. Modal and frequency analysis of the machine with a computer model allows making a preliminary assessment of the level of vibration during the design phase [3, 4, 5].

2. Research methodology

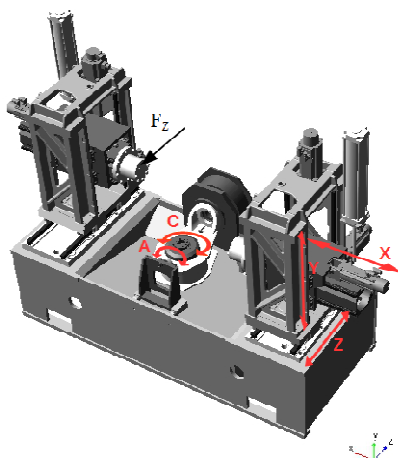

In this article, the object of investigation is a five-axis horizontal two-spindle CNC machining center (Figure 1). To develop a virtual machine model, the MSC.Adams software environment was chosen because of its integration with finite element modeling systems, the MATLAB software and the availability of a specialized module for performing frequency analysis Adams/Vibration [6].

Figure 1. The carrier system of the machine in MSC.Adams



The machine carrier system includes four aggregate modules. There are two racks on the frame with spindle headstocks and a two-axis rotary table. The machine is designed for machining parts in five axes: the X axis - the tangential tool advance; Y axis - vertical tool advance; axis Z - radial tool advance; axis A – table turn; axis C - rotation of the faceplate. All linear axes of the machine are equipped with servomotors with direct screw drive and ball-and-screw units (BSU) with preload. In the spindle head there is an electric spindle, in front and tail support of which radial-thrust hybrid ceramic bearings are mounted. Bearing structural elements are made of steel with density $\rho = 7.8 \cdot 10^{-3}$ kg/cm³, modulus of elasticity $E = 2.07 \cdot 10^7$ N/cm² and Poisson's ratio $\mu = 0.29$. For BSU, rolling-contact bearing of guides and supports for the drives of the X, Y, Z axes, the elastic modulus is taken less than for steel because they have low contact rigidity [7].

In the Adams/View [8], the kinematic connections of the elements of the machine support system developed in the COMPAS system are shown in Table 1.

Table 1. Elements used for constructing a dynamic model

Type of finite element		Amount of elements	Function
Elements (Parts)	Rigid body (RigidBody)	62	Carrier machine elements
Joints (Joints)	Fixed joint (Fixed Joint)	11	Rigid connections (installation of the machine on the foundation, etc.)
	Translational joint (TranslationalJoint)	6	Tool advance
	Revolute joint (RevoluteJoint)	4	Table turn, rotation of faceplate, rotation of spindle
Motion laws (Motions)	Rotational motion (Rotational Motion)	1	Connections of the turning table and bracket assembly, chuck for parts
	Translational motion (Translational Motion)	1	Connections of rail guides and support
Bearings(Bearing)	Compliant (Compliant)	10	Bearings of drives of advance and table, spindle joints
Forces (Forces)	Fixing simulator with a certain rigidity (Bushing)	8	Tool and detail clamping, BSU

Bearing module is used to specify the bearings, the diameter of the pin, stiffness, damping coefficient and preload are set, which will allow to model the radial beat of the spindle in supports for the milling.

The working range of spindle rotation is $n_{sp} = 80 \div 6000$ min⁻¹, which corresponds to frequencies $f_{sp} = 1.3 \div 100$ Hz. The frequencies of the turning table drives and advances are in this range. The vibration analysis of the machine is carried out for the case of steady-state oscillatory processes, that is, the spindle rotation speed and feedrate are assumed to be constant in the calculation. The spindle unit overhang is 200 mm. As the spindle unit overhang increases, the dynamic stiffness of the spindle changes and the amplitude of vibration increase.

The minimum frequency of disturbing oscillations: $f_{min} = n_{min} \cdot z/60 = 2.67$ Hz, the maximum frequency is $f_{max} = n_{max} \cdot z/60 = 200$ Hz, where n_{min}, n_{max} is the minimum and maximum rotational speeds of the moving parts of the machine, z is the number of teeth of the mill ($z = 2$).

The Adams/Vibration module linearizes non-linear model $G(x, \dot{x}, t) = 0$, where x is the variable state of the object (displacement and velocity of the elements of the machine carrier system) in the vicinity of the initial state in the form:

$$\begin{cases} sX(s) = AX(s) + BU(s) \\ Y(s) = CX(s) + DU(s) \end{cases},$$

where U – inputs of the linear model, Y – model outputs, X – state vector of the model.

For the modal analysis, the model is presented in the form of a system of differential equations $\dot{X} = AX$, which solution is $x(t) = \xi^i \cdot e^{\lambda^i t}$, where the ξ^i - i -th is eigenvector, λ^i - i -th is the eigenvalue $\lambda^i = \lambda_r^i + i\lambda_i^i$. Figure 2 shows the eigenvectors of the system, where each point corresponds to the i -th eigenfrequency $f^i = \sqrt{(\lambda_r^i)^2 + (\lambda_i^i)^2}$ of the system's oscillations.

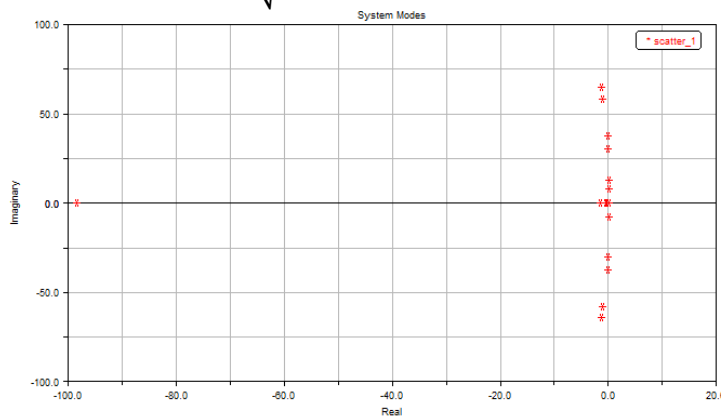

Figure 2. Eigen forms of machine oscillations

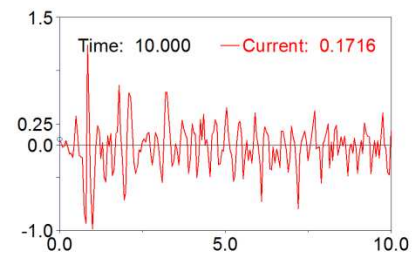

Figure 3. Vibrogram of spindle oscillations during cutting

Excluding too small frequencies, the authors selected 7 eigenfrequencies shown in Table 2.

Table 2. Eigen oscillation types of system

Number	f_0 , Hz	Mode	Damping ratio	Real part	Imaginary part
1	7.91	Rocking of the carrier system relative to the foundation	0.004	-0.035	-7.91
2	15.97	Antiphase movement of the left and right racks	0.0076	-0.045	-15.96
3	30.39	Rocking of the spindle unit along the Y axis	0.006	-0.197	-30.388
4	37.66	Rocking of the spindle unit along the X axis	0.0034	-0.128	-37.66
5	58.11	Rocking of the spindle rack along the Z axis	0.018	-1.06	-58.1
6	64.45	Flank movements of the spindle unit in the XY plane	0.02	-1.3	-64.44
7	98.58	Torsional oscillations of the spindle head	1	-98.58	0

In the vibration analysis, the input from elastic system $F(t)$ receives a signal of cutting process $F_Z = A_Z \cdot \sin 2\pi ft$, where A_Z is the amplitude of the driving force, f is the frequency of the driving force, and the relative displacements of the spindle at the output [9, 10].

Figure 3 shows the amplitude of the oscillations of the machine spindle along the X axis at a frequency of the driving force of 20 Hz.

The transfer function of the system under study can be represented as $H(s) = \frac{Y(s)}{U(s)} = C(sI - A)^{-1}B + D$. To obtain frequency response $Y(s) = H(s) \cdot U(s)$ of the Adams / Vibration system, the frequency of the exciting force varied within predetermined limits in order to search for all the resonant regimes in this area (Figure 4).

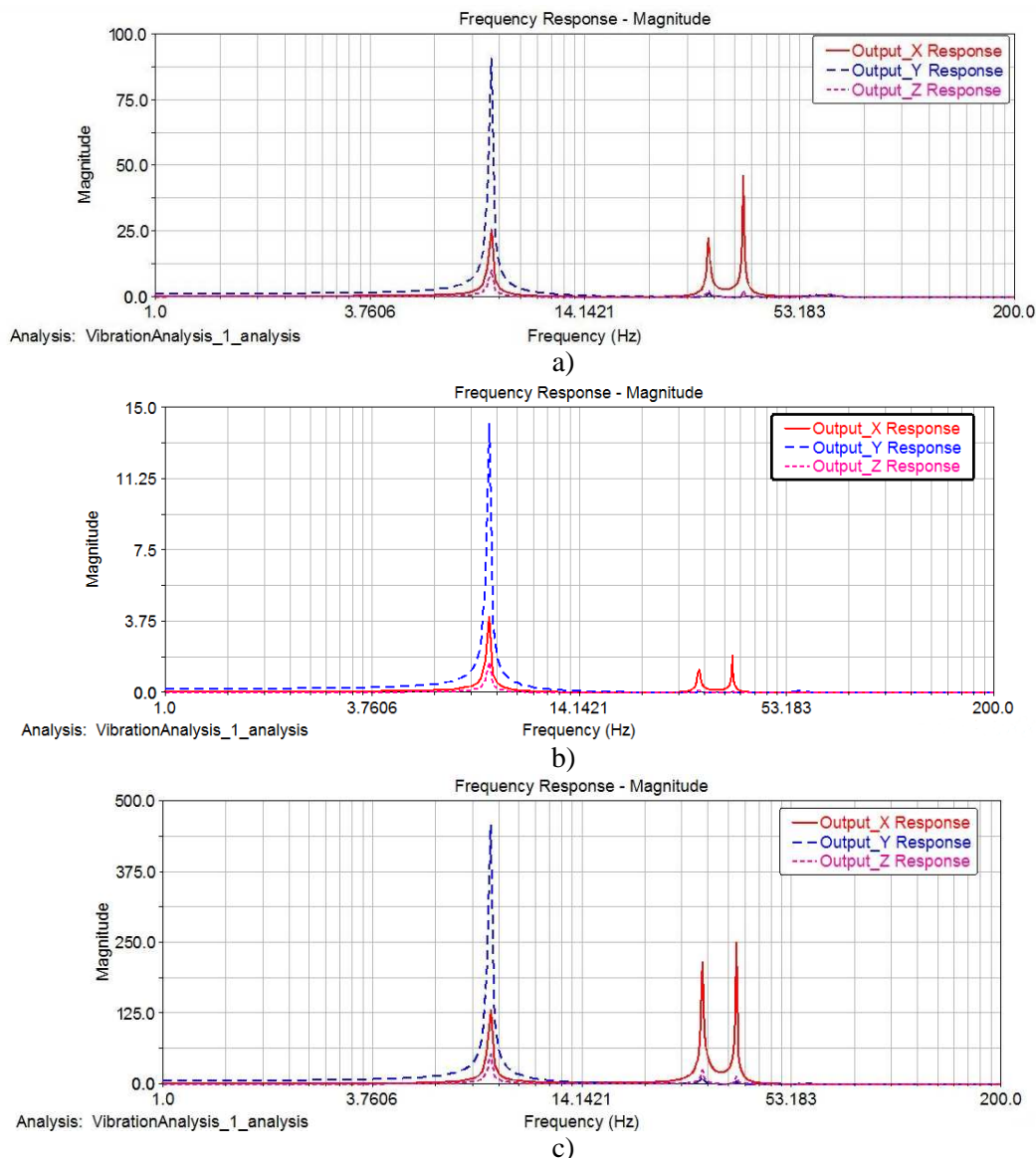

Figure 4. Amplitude-frequency characteristic of spindle movements in X, Y, Z (μm) with axial (a, F_X), vertical (b, F_Y) and longitudinal (c; F_Z) exciting force

The maximum amplitude peak is $452 \mu\text{m}$, which in accordance with GOST ISO 7919-3-2002 is unfavorable for long-term operation of the machine [11].

The amplitude-frequency characteristic of the carrier system of the machine is obtained with two main components of the cutting force of the machine (Figure 5).

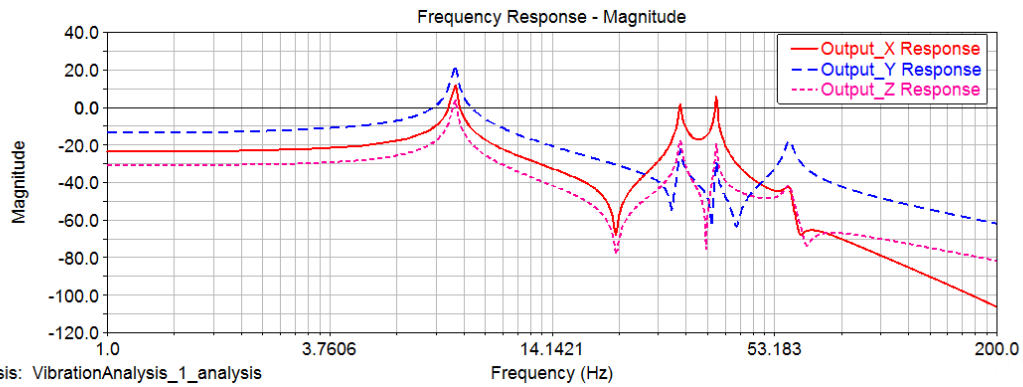

Figure 5. Spindle movement amplitude-frequency characteristics in Z (dB) with vertical (FY) exciting force

Figure 6 shows which of the eigenmodes for driving force F_Y have high values of modal coordinates $X(s) = (sI - A)^{-1}BU$.

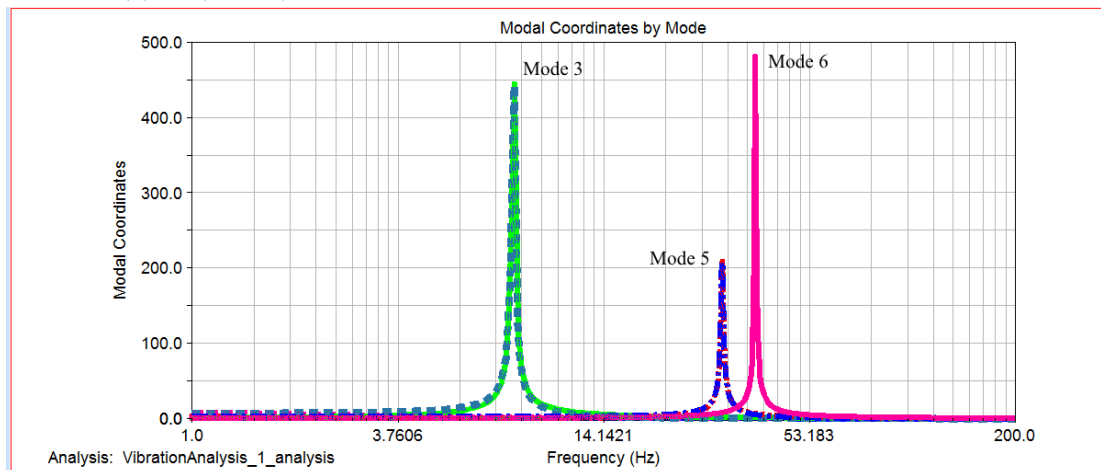

Figure 6. Modal coordinates corresponding to the input signal in the vertical (Y) direction

The spectral density of the output signal (PowerSpectralDensity, PSD) is also determined $P(s) = H^T(s) \cdot U(s) \cdot H(s)$ (Figure 7).

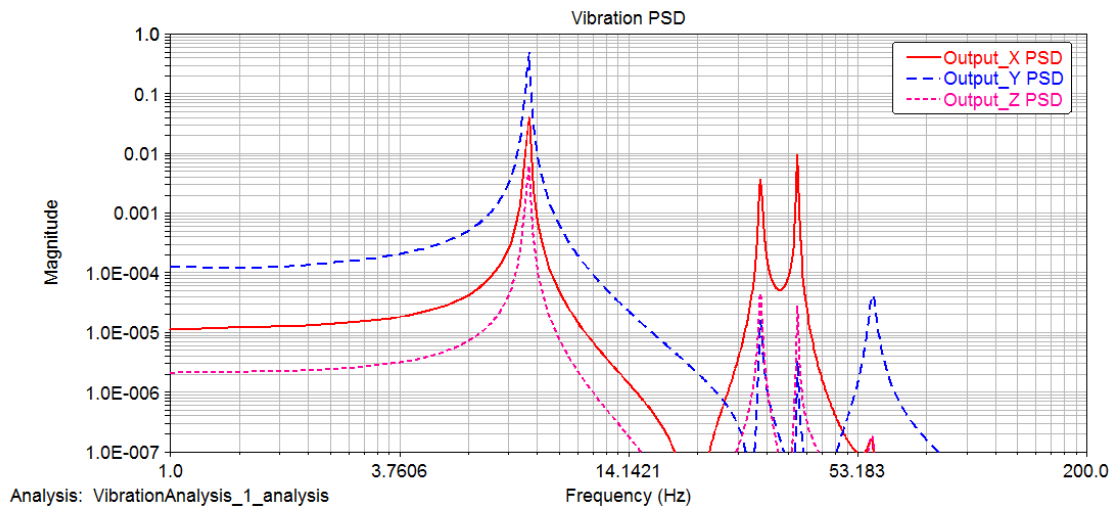

Figure 7. Frequency spectrum of the vibration displacement of the spindle

3. Conclusion

The analysis of the dynamics of the machining center showed that the resonance amplitudes of the oscillations correspond to frequencies of 7..10 Hz and 58.65 Hz, the maximum was observed in the direction of the Z axis. Thus, the work of the machine at these frequencies will lead to large oscillation amplitudes of the elements of the technological system and have a negative impact on the accuracy of the dimensions and the roughness of the treated surface. For a stable cutting process, it is necessary to exclude the purpose of cutting modes that cause such resonance frequencies. The obtained amplitude- and phase-frequency dependences allow one to design the regime of exploitation of the machine system taking into account its dynamic characteristics. This technique for analyzing frequency characteristics can be applied to any machine.

4. Acknowledgments

The article was prepared within the development program of the Flagship Regional University on the basis of Belgorod State Technological University named after V.G. Shoukhov, using equipment of High Technology Center at BSTU named after V.G. Shoukhov

References

- [1] Kudinov V A 1967 *Dynamics of machine tools* (Moscow: Mechanical Engineering)
- [2] Popov V I, Loktev V I 1975 *Dynamics of machine tools* (Kiev: Engineering)
- [3] Vasilevich Y V, Dovnar S S, Truskovsky A S, Shumsky I I 2015 *Science & Technique* **3** 9–19
- [4] Vasilevich Y V, Dovnar S S 2015 *Science & Technique* **5** 10–17
- [5] Boltian A V, Boltian M A 2011 *Progressive technologies and systems of mechanical engineering* **41** 51–57
- [6] <http://www.mscsoftware.com/product/adams>
- [7] Sankin Yu N, Sankin N Yu 2008 *Stability of lathes with a nonlinear characteristic of the cutting process* (Ulyanovsk: UISTU)
- [8] Melentiev B C, Gvozdev A S 2006 *ADAMS/View, ADAMS/PostProcessor: quick user guide* (Samara: Publishing house Samara State Aerospace University)
- [9] Ignatiev S A, Karakozova V A, Ignatiev A A 2008 *Automation and control in machine and instrument engineering* (Saratov: SSTU) 80–85
- [10] Ignatiev A A, Dobryakov V A, Ignatiev S A 2005 *STIN* **7** 3–7
- [11] GOST ISO 7919-3-2002