

PAPER • OPEN ACCESS

## Theoretical study of cut area of reduction of large surfaces of rotation parts on machines with rotary cutters “Extra”

To cite this article: J A Bondarenko *et al* 2018 *IOP Conf. Ser.: Mater. Sci. Eng.* **327** 042019

View the [article online](#) for updates and enhancements.



**IOP | ebooks™**

Bringing you innovative digital publishing with leading voices to create your essential collection of books in STEM research.

Start exploring the [collection](#) - download the first chapter of every title for free.

# Theoretical study of cut area of reduction of large surfaces of rotation parts on machines with rotary cutters “Extra”

**J A Bondarenko, M A Fedorenko, A A Pogonin**

Belgorod State Technological University after V.G. Shukhov, Kostyukova St., 46, Belgorod, 308012, Russia

E-mail: kdsm2002@mail.ru

**Abstract.** Large parts can be treated without disassembling machines using “Extra”, having technological and design challenges, which differ from the challenges in the processing of these components on the stationary machine. Extension machines are used to restore large parts up to the condition allowing one to use them in a production environment. To achieve the desired accuracy and surface roughness parameters, the surface after rotary grinding becomes recoverable, which greatly increases complexity. In order to improve production efficiency and productivity of the process, the qualitative rotary processing of the machined surface is applied. The rotary cutting process includes a continuous change of the cutting edge surfaces. The kinematic parameters of a rotary cutting define its main features and patterns, the cutting operation of the rotary cutting instrument.

## 1. Introduction

In the modern mechanical engineering, a significant number of parts are fabricated from lead-tin-base bronzes. They include a series of parts, which should possess sufficiently advanced strength characteristics (sealings and piston rings, oil-seal and expander rings). In order to enhance tribotechnical characteristics, lead is introduced into these materials. Lead reduces friction coefficient, enhances tribotechnical characteristics; however, it reduces strength significantly.

At present, one of the promising trends of enhancing a set of service properties of such bronzes is alloying them with superdispersed powders (SDP). Introduction of their small amount into the melt before a crystallization process allows increasing strength properties of castings [1, 2]. But a mechanism of interaction with lead-tin-based bronzes, as well as the process regularities of such modification, is not studied profoundly. However, such modification of copper alloys is promising from several points of view.

This paper presents an investigation of the influence of different contents of additives of the pre-treated aluminium oxide powder on the structure of lead-tin-base bronze under formation.

## 2. Informative Part

A rotary cutter as a result of tolerances has a radial and axial wear. As a result, the processing on the surface appears to be a periodical recurring transverse and longitudinal wave-like spiral. Longitudinal undulations coincide with the forming of the cylindrical surface and are close to the angle of the cutting edge. At the top, the longitudinal and transverse waves differ slightly, but they differ in step. With the increase of the cutting speed, the ripple increases as well [4].



The treated surface of the part has a pronounced elongated structure, which is formed by the interaction of the normal force and the friction force between the back surface of the cutting tool and the rotary cup component surface. It occurs under the action of plastic deformation of the surface layer in the direction of movement of the cutter [5]. At the angle of the cutting traces in the diagram of dependences, there is a flow and a depth of the cut. The angle of the texture allows one to evaluate the ability of the tool to autorotate in different cutting conditions.

The results of the treatments with the components on auxiliary machines of cup cutters with positive rotation showed that this treatment process provides the necessary geometrical accuracy.

Determination of processing accuracy of the worn cylindrical surface allows developing a mathematical model of a rotary processing optimization. The accuracy and quality of recoverable surface depend on various factors including process parameters and modes of cutting parts [6].

To determine the angles of the rotary cutter, sharpening angles, the diameter of the cutting plates, cutting conditions and the actual performance of the cutoff area were considered. It is obtained by the intersection of the cone cups of the cutting tool and the surface details of various shapes [7, 8].

### 3. Treating the surface of rotating shaped catenoid

Let us introduce the following notation:  $\varphi$  - the angle between the cone axis and axis  $OY$  (the angle of rotation of the cutting cup axis in the horizontal plane);  $\gamma$  - the angle between the height and the angle of the cone;  $\omega$  - the angle between the axis and the radius of the normal section catenoid contained in the point of contact with the cone (angle of the cutting installation of a cup in a vertical plane);  $r$  - the radius of the cone;  $c$  - the height of the cone of the cup cutter;  $H$  - the distance from the center of the cone to the axis or the distance from the point of contact with the cone to the axis;  $R_1$  - the distance between the center of the cone and the normal section catenoid;  $R = mch \frac{(x-l/2)}{d}$  - the radius of the normal section catenoid;  $t$  - depth of cut.

The general equation of the cone is:

$$\frac{(x-x_0)^2}{a^2} + \frac{(y-y_0)^2}{b^2} + \frac{(z-z_0)^2}{c^2} = 0$$

Let us carry out the conversion; then the equation of the cone will be:

$$\begin{aligned} & \left[ \frac{x - r \cdot \cos \varphi - \left( m \cdot ch \left( \frac{x-l/2}{d} \right) \cdot \cos \omega - t \right) \operatorname{tg} \varphi - r \cdot \operatorname{ctg} \gamma \cdot \cos \varphi}{r^2} \right]^2 + \\ & + \left[ \frac{z + m \cdot ch \left( \frac{x-l/2}{d} \right) \cdot \sin \omega + r \cdot \cos \operatorname{arctg} \operatorname{tg} \omega / \sin \varphi}{r^2} \right]^2 - \\ & - \left[ \frac{y + r \cdot \sin \varphi - m \cdot ch \left( \frac{x-l/2}{d} \right) \cdot \cos \omega + t - r \cdot \operatorname{ctg} \gamma \cdot \cos \varphi}{c^2} \right]^2 = 0 \end{aligned}$$

Let us equate the treated surface of large parts and the shaped catenoid:

$$y^2 + z^2 = m^2 \cdot ch^2 \left( \frac{x-l/2}{d} \right)$$

The system of equations of the cone of the cutting tool and the cup catenoid, defining the shape of

the surface of the restored parts, determines the equation of the curve of intersection of these bodies:

$$\left\{ \begin{array}{l} \left[ \frac{x - r \cdot \cos \varphi - \left( m \cdot ch \left( \frac{x-l/2}{d} \right) \cdot \cos \omega - t \right) tg \varphi - r \cdot ctg \gamma \cdot \cos \varphi}{r^2} \right]^2 + \\ + \left[ \frac{z + m \cdot ch \left( \frac{x-l/2}{d} \right) \cdot \sin \omega + \cos \arctg tg \omega / \sin \varphi}{r^2} \right]^2 - \\ - \left[ \frac{y + r \cdot \sin \varphi - m \cdot ch \left( \frac{x-l/2}{d} \right) \cdot \cos \omega + t - r \cdot ctg \gamma \cdot \cos \varphi}{c^2} \right]^2 = 0 \\ y^2 + z^2 = m^2 \cdot ch^2 \left( \frac{x-l/2}{d} \right) \end{array} \right.$$

From this expression, one obtains:

$$y = \pm \sqrt{m^2 \cdot ch^2 \left( \frac{x-l/2}{d} \right) - z^2}$$

To determine the area of the cut (Figures 1, 2), let us use the expression:

$$z = \left\{ r^2 [y + r \cdot \sin \varphi - R \cdot \cos \omega + t - r \cdot ctg \gamma \cdot \cos \varphi]^2 - \right. \\ \left. - c^2 [x - r \cos \varphi - (R \cos \omega - t) tg \varphi - r ctg \gamma \sin \varphi]^2 \right\}^{\frac{1}{2}} c^{-1} - H$$

It is possible to find  $\frac{\partial z}{\partial x}$ ,  $\frac{\partial z}{\partial y}$  in the following way:

$$\frac{\partial z}{\partial y} = c^{-1} \left\{ r^2 [y \cdot \sin \varphi - R \cdot \cos \omega + t - r \cdot ctg \gamma \cdot \cos \varphi]^2 - \right. \\ \left. - c^2 [x - r \cos \varphi - (R \cos \omega - t) tg \varphi - r \cdot ctg \gamma \cdot \sin \varphi]^2 \right\}^{\frac{1}{2}} \cdot \\ \cdot r^2 [y + r \sin \varphi - R \cos \omega + t - r ctg \gamma \cos \varphi]$$

$$\begin{aligned}
\frac{\partial z}{\partial x} = & (cr^2)^{-1} \left\{ r^2 \left[ y \cdot \sin \varphi - \left( \frac{m \cdot ch\left(\frac{x-l/2}{d}\right) \cos \omega - t}{\cos \varphi} + r \cdot ctg \gamma \right) \cdot \cos \varphi \right]^2 - \right. \\
& \left. - c^2 \left[ x - r \cos \varphi - \left( m \cdot ch\left(\frac{x-l/2}{d}\right) \cos \omega - t \right) tg \varphi - r \cdot ctg \gamma \cdot \sin \varphi \right]^2 \right\}^{\frac{1}{2}} \cdot \\
& \left\{ r^2 \left[ y + r \sin \varphi - \left( m \cdot ch\left(\frac{x-l/2}{d}\right) \cos \omega - t \right) - r \cdot ctg \gamma \cdot \cos \varphi \right] \cdot \left[ -\frac{m}{d} sh\left(\frac{x-l/2}{d}\right) \cos \omega \right] - \right. \\
& \left. c^2 \left[ x - r \cos \varphi - \left( m \cdot ch\left(\frac{x-l/2}{d}\right) \cos \omega - t \right) tg \varphi - r \cdot ctg \gamma \cdot \sin \varphi \right] \cdot \left[ 1 - \frac{m}{d} sh\left(\frac{x-l/2}{d}\right) \cos \omega \cdot tg \varphi \right] \right\} \\
\frac{\partial z}{\partial x} = & (cr^2)^{-1} \left\{ r^2 \left[ y \cdot \sin \varphi - \left( \frac{m \cdot ch\left(\frac{x-l/2}{d}\right) \cos \omega - t}{\cos \varphi} + r \cdot ctg \gamma \right) \cdot \cos \varphi \right]^2 - \right. \\
& \left. - c^2 \left[ x - r \cos \varphi - \left( m \cdot ch\left(\frac{x-l/2}{d}\right) \cos \omega - t \right) tg \varphi - r \cdot ctg \gamma \cdot \sin \varphi \right]^2 \right\}^{\frac{1}{2}} \cdot \\
& \left\{ r^2 \left[ y + r \sin \varphi - \left( m \cdot ch\left(\frac{x-l/2}{d}\right) \cos \omega - t \right) - r \cdot ctg \gamma \cdot \cos \varphi \right] \cdot \left[ -\frac{m}{d} sh\left(\frac{x-l/2}{d}\right) \cos \omega \right] - \right. \\
& \left. c^2 \left[ x - r \cos \varphi - \left( m \cdot ch\left(\frac{x-l/2}{d}\right) \cos \omega - t \right) tg \varphi - r \cdot ctg \gamma \cdot \sin \varphi \right] \cdot \left[ 1 - \frac{m}{d} sh\left(\frac{x-l/2}{d}\right) \cos \omega \cdot tg \varphi \right] \right\}
\end{aligned}$$

where

$$R = m \cdot ch\left(\frac{x-l/2}{d}\right) \quad R' = \frac{m \cdot ch\left(\frac{x-l/2}{d}\right) \cos \omega - t}{\cos \varphi}$$

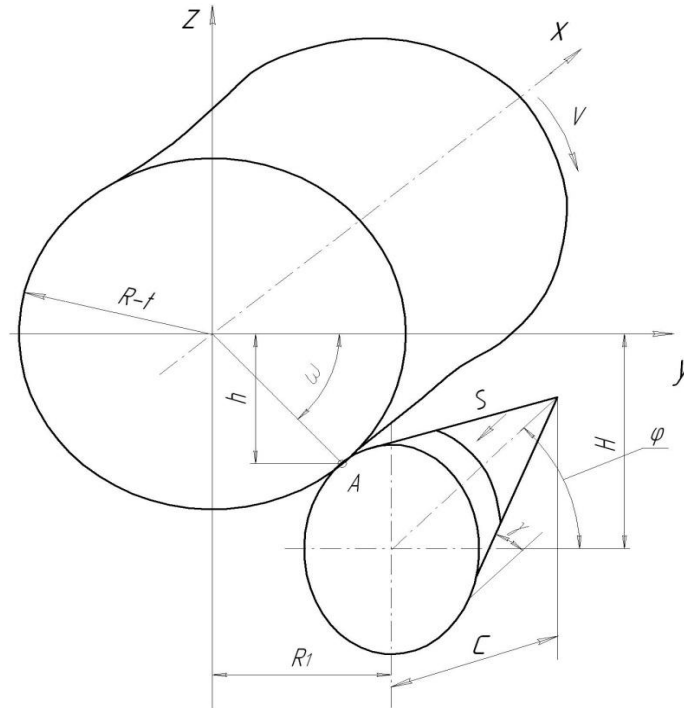

**Figure 1.** Location of the cutting tool relative to the treated surface of the cup-shaped catenoid

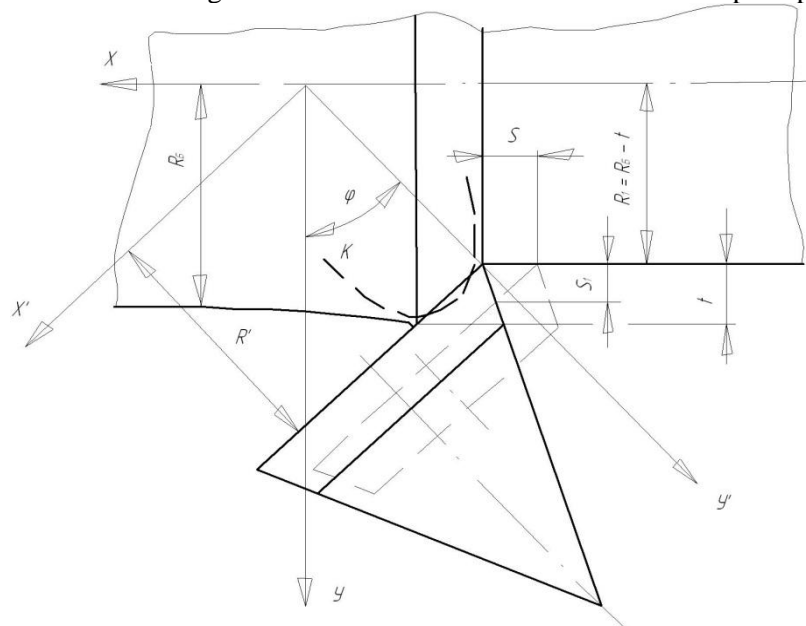

**Figure 2.** Cutting the surface treatment area, having the shape of a catenoid  
Let us calculate the area cut by the formula:

$$P = \int_{R_1 = mch\left(\frac{x-l/2}{d}\right) \cos \omega - t}^{R_2 = mch\left(\frac{x-l/2}{d}\right) \cos \omega} dy \int_0^x \sqrt{1 + \left(\frac{\partial z}{\partial x}\right)^2 + \left(\frac{\partial z}{\partial y}\right)^2} dx$$

This equation with the boundaries of integration is as follows:

$$R_1 = m \cdot ch\left(\frac{x-l/2}{d}\right) \cos \omega - t \quad R_2 = m \cdot ch\left(\frac{x-l/2}{d}\right) \cos \omega$$

where the shear area is used to determine the processing of metal parts, having the shape of a catenoid, that allows one to determine the installation angles and geometric tool parameters.

Let us consider the impact of factors on the cutting area during the rotary machining of the workpiece, having a shape of a truncated cone (Fig. 3.4).

The equation of a truncated cone in the specified coordinate system will be:

$$\frac{y^2}{R_0^2} + \frac{z^2}{R_0^2} - \frac{(x+L+l)^2}{(L+l)^2} = 0$$

To find the relations for the values of length and a radius, let us use:

$$\frac{y^2}{R_0^2} + \frac{z^2}{R_0^2} = \frac{\left(x + \frac{LR_0}{R_0 - r_0}\right)^2}{\left(\frac{LR_0}{R_0 - r_0}\right)^2}$$

In this coordinate system, the cutting tool equation of the cup-shaped truncated cone can be written as follows:

$$\frac{x'}{r^2} + \frac{z'}{r^2} - \frac{(y' - l_x)^2}{l_k^2} = 0$$

During operation, the rotary cutter, the cutting tool are rotated by cup torque cutting and friction forces.

After the transformation equation, the cup rotary cutter will be:

$$\frac{(x-x_0)^2}{r^2} + \frac{(z-z_0)^2}{r^2} - \frac{(y-y_0)^2}{l_k^2} = 0$$

where coordinates  $x'$  and  $y'$  are connected with  $x$  and  $y$  coordinates by the following relations:

$$\begin{aligned} x_0 &= x'_0 \cos \varphi + y'_0 \sin \varphi, \\ y_0 &= y'_0 \cos \varphi - x'_0 \sin \varphi. \end{aligned}$$

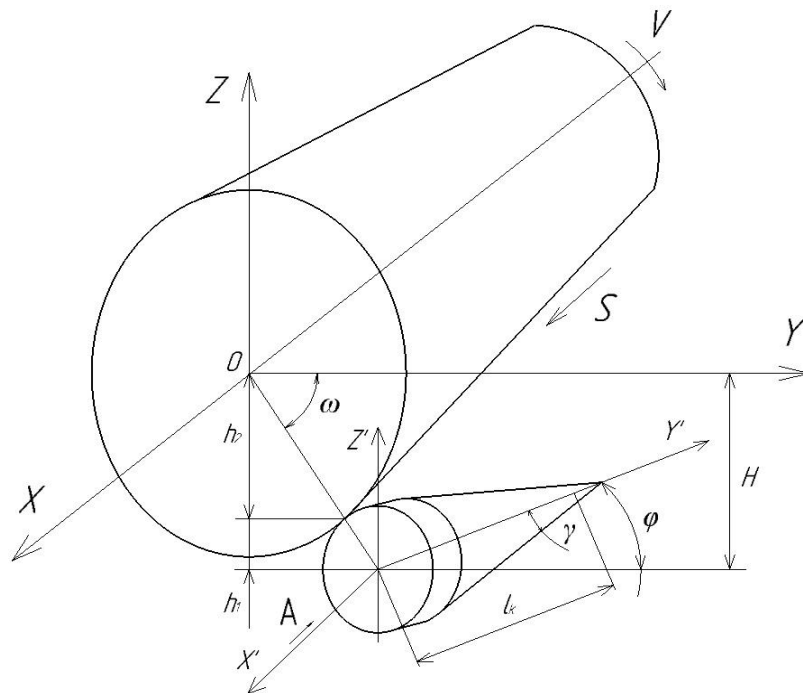

**Figure 3.** Location of the cutting tool with respect to the treated surface of the cup having a conical shape

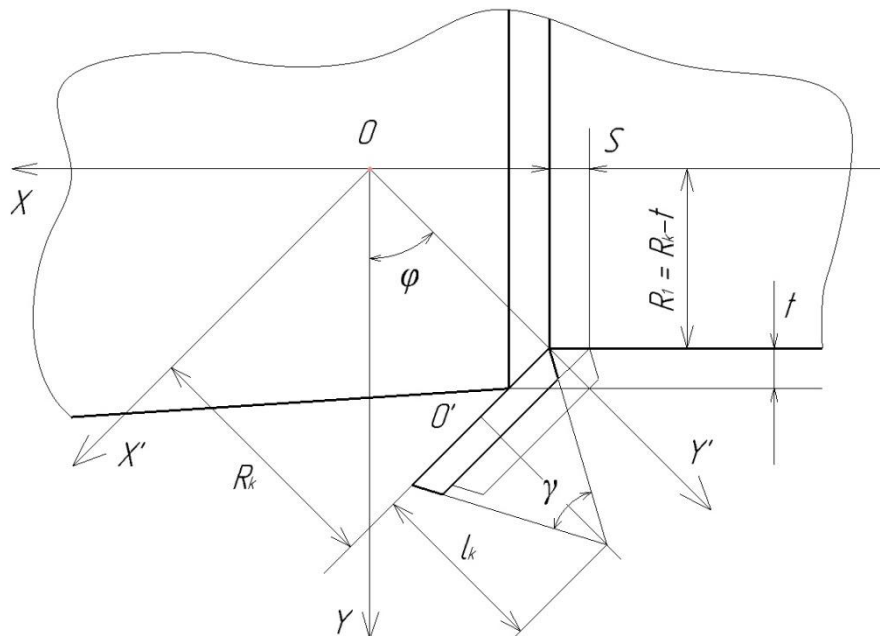

**Figure 4.** A scheme of the cutoff area by surface treatment having a shape of a cone  
After transformations:

$$x_0 = r \cos \varphi + \left( \frac{R_k \cos \omega - t}{\cos \varphi} + r \operatorname{ctg} \gamma \right) \sin \varphi$$

$$y_0 = -r \sin \varphi + \left( \frac{R_k \cos \omega - t}{\cos \varphi} + r \operatorname{ctg} \gamma \right) \cos \varphi$$

Let us get the following:



$$\begin{aligned} & \left[ x - r \cos \varphi - \left( \left( R_0 - \frac{R_0 - r_0}{L} \varepsilon \right) \cos \omega - t \right) \operatorname{tg} \varphi - r \operatorname{ctg} \gamma \sin \varphi \right]^2 + \\ & \quad + \left[ z + \left( R_0 - \frac{R_0 - r_0}{L} \varepsilon \right) \sin \omega + r \cos \psi \right]^2 = \\ & = \left[ y + r \sin \varphi - \left( R_0 - \frac{R_0 - r_0}{L} \varepsilon \right) \cos \omega + t - r \operatorname{ctg} \gamma \cos \varphi \right]^2 \operatorname{tg}^2 \gamma = 0. \end{aligned}$$

Let us take into account that:

$$\cos \psi = \cos \left( \operatorname{arctg} \left( \frac{\operatorname{tg} \omega}{\sin \varphi} \right) \right) = \frac{1}{\sqrt{1 + \frac{\operatorname{tg}^2 \omega}{\sin^2 \varphi}}}$$

Thus, there is the following equation:

$$\begin{aligned} & \left[ x - r \cos \varphi - \left( \left( R_0 - \frac{R_0 - r_0}{L} \varepsilon \right) \cos \omega - t \right) \operatorname{tg} \varphi - r \operatorname{ctg} \varphi \sin \varphi \right]^2 + \\ & \quad + \left[ z + \left( R_0 - \frac{R_0 - r_0}{L} \varepsilon \right) \sin \omega + \frac{r}{\sqrt{1 + \frac{\operatorname{tg}^2 \omega}{\sin^2 \varphi}}} \right]^2 = \\ & = \left[ y + r \sin \varphi - \left( R_0 - \frac{R_0 - r_0}{L} \varepsilon \right) \cos \omega + t - r \operatorname{ctg} \gamma \cos \varphi \right]^2 \operatorname{tg}^2 \gamma. \end{aligned}$$

Surfaces of the treated detail, having a cone shape and the surface of the cutting tool plates, intersect along the curve. An equation that describes the system of equations is as follows:

$$\left\{ \begin{aligned} & \frac{y^2}{R_0^2} + \frac{z^2}{R_0^2} = \frac{\left(x + \frac{LR_0}{R_0 - r_0}\right)^2}{\left(\frac{LR_0}{R_0 - r_0}\right)^2}; \\ & \left[ x - r \cos \varphi - \left( \left( R_0 - \frac{R_0 - r_0}{L} \varepsilon \right) \cos \omega - t \right) \operatorname{tg} \varphi - r \operatorname{ctg} \gamma \sin \varphi \right]^2 + \\ & \quad + \left[ z + \left( R_0 - \frac{R_0 - r_0}{L} \varepsilon \right) \sin \omega + \frac{r}{\sqrt{1 + \frac{\operatorname{tg}^2 \omega}{\sin^2 \varphi}}} \right]^2 = \\ & = \left[ y + r \sin \varphi - \left( R_0 - \frac{l_0 - r_0}{L} \varepsilon \right) \cos \omega + t - r \operatorname{ctg} \gamma \cos \varphi \right]^2 \operatorname{tg}^2 \gamma \end{aligned} \right.$$

After transformations, let us find:

$$\left\{ \begin{aligned} & \left[ x - r \cos \varphi - \left( \left( R_0 - \frac{R_0 - r_0}{L} \varepsilon \right) \cos \omega - t \right) \operatorname{tg} \varphi - r \operatorname{ctg} \gamma \sin \varphi \right]^2 + \\ & \quad + \left[ z + \left( R_0 - \frac{R_0 - r_0}{L} \varepsilon \right) \sin \omega + \frac{r}{\sqrt{1 + \frac{\operatorname{tg}^2 \omega}{\sin^2 \varphi}}} \right]^2 = \\ & = \left[ \sqrt{\frac{\left(x + \frac{LR_0}{R_0 - r_0}\right)^2}{L^2} - z^2} + r \sin \varphi - \left( R_0 - \frac{R_0 - r_0}{L} \varepsilon \right) \cos \omega + t - \right. \\ & \quad \left. - r \operatorname{ctg} \gamma \cos \varphi \right]^2 \operatorname{tg}^2 \gamma \end{aligned} \right.$$

Then the curve of intersection of surfaces with the machined surface has the shape of a cup cone of the cutting tool:

$$\left\{ \begin{aligned} & \left[ x - r \cos \varphi - \left( \left( R_0 - \frac{R_0 - r_0}{L} \varepsilon \right) \cos \omega - t \right) \operatorname{tg} \varphi - r \operatorname{ctg} \gamma \sin \varphi \right]^2 + \\ & \quad + \left[ \left( R_0 - \frac{R_0 - r_0}{L} \varepsilon \right) \sin \omega + \frac{r}{\sqrt{1 + \frac{\operatorname{tg}^2 \omega}{\sin^2 \varphi}}} \right]^2 = \end{aligned} \right.$$

$$= \left[ \frac{x + \frac{LR_0}{R_0 - r_0}}{\frac{R_0 - r_0}{L}} + r \sin \varphi - \left( R_0 - \frac{R_0 - r_0}{L} \varepsilon \right) \cos \omega + t - r \operatorname{ctg} \gamma \cos \varphi \right]^2 \operatorname{tg}^2 \gamma$$

The surface area of the cutter blade cut of the cup in a single pass can be determined as:

$$S = \int_{R_0}^{r_0} dy \int_0^{x_1} \sqrt{1 + \left( \frac{dz}{dx} \right)^2 + \left( \frac{dz}{dy} \right)^2} dx$$

The final formula is related to the cut area [7]:

$$S = \int_{R_0}^{r_0} dy \int_0^{x_1} \sqrt{1 + \frac{B_1(x) + B_2(y) \operatorname{tg}^2 \gamma}{B_2(y) - B_1(x)}} dx$$

#### 4. Conclusion

Thus, the equation allows one to calculate the surface area of the cup shear cutting, which is formed in a single pass surface treatment part, having a shape and catenoid in the form of a truncated cone. The following has been found:

1. Determination of the spatial position of the cutting cup rotary cutter relative to the product surface and revealing the relationship between their coordinate systems, allowing them to determine the relative position and interference during operation.
2. Mathematical relationship that defines the equation of motion of the tool to ensure cylindricity of large parts with treatment of the surface shaped as a catenoid.
3. Mathematical relationship that defines the equation of motion of the tool to ensure cylindricity of large parts with treatment of the surface having the shape of a truncated cone.
4. Determination of the ratio to calculate the surface area of the cutting tool cup cut formed in a single pass processing of large parts with a surface shaped as a catenoid.
5. Correlation for calculating the surface area of the cutting tool, cutting plates formed in a single pass processing of large parts with a surface shaped as a truncated cone.
6. Dependence of the cutoff area when changing the radius of the cutting plates, when moving along the surface of the last product.

#### References

- [1] Fedorenko T M, Fedorenko M A and Bondarenko Y A 2009 *Journal of Technology of mechanical engineering* **3** 20-21
- [2] Fedorenko M A, Bondarenko Y A, Sanina T M and Markova O V 2015 *Journal of Engineering Technology* **11** 27-28
- [3] Bestuzheva O V, Bondarenko Y A and Fedorenko M.A 2016 *Journal of Bulletin BSTU named after VG Shukhov* **12** 121-126
- [4] Bondarenko Y A, Fedorenko T M and Fedorenko M A 2008 *The machine for processing pins grinding mills - The patent for utility model number 75339 cl. IPC V23V5 / 00, № 2008104754/22*
- [5] Bans F G and Nivizhsky O A 1975 *Mechanical equipment of cement plants: a textbook for colleges*. (Moscow: Engineering)
- [6] Yascheritsyn P I, Borisenko A V, Drivotin I G and Lebedev V Y 1987 *Rotary cutting materials*. (Moscow: Science and Technology)
- [7] Boganov A I 1961 *Mechanical equipment of cement plants: studies. Guide for chemical specialties. tehnol. universities and facts*. (Moscow: Mashgiz)
- [8] Nesvizhsky O A 1968 *The durability of wearing parts cement equipment*. (Moscow: Engineering)